



City of Napoleon, Ohio

Zoning Department

255 West Riverview Avenue, P.O. Box 151
Napoleon, OH 43545

Kevin Schultheis Code Enforcement / Zoning Administrator
Telephone: (419) 592-4010 Fax: (419) 599-8393
www.napoleonohio.com

COMMERCIAL ZONING PERMIT

Issued Date: June 22, 2023

Expiration Date: June 22, 2024

Permit Number: P-23-093

Job Location: 910 Third Street

Owner: GLCAP (Kid's Castle LLC)
910 Third Street
Napoleon, OH 43545

Contractor: Self
Phone: 567-202-2345 or 419-360-0583 (Maria-Center Specialist)

Zone: Modern Density Residential

Set Backs: Accessory Building: Front Yard: 40' Rear Yard: 10' Side Yard: 7'

Comments: Installing a 12x10 gazebo and attaching to existing cement pad

Permit Type: Accessory Building

Fee: \$0.00

Status: Waived

Amount Due: \$0.00

Kevin Schultheis
Code Enforcement/Zoning Administrator



City of Napoleon, Ohio

P-23-093
R3

Zoning Department

255 West Riverview Avenue, P.O. Box 151

Napoleon, OH 43545

Kevin Schultheis Code Enforcement / Interim Zoning Administrator

Telephone: (419) 592-4010 Fax: (419) 599-8393

www.napoleonohio.com

Commercial Zoning Permit Application

Date 6/21/23 Job Location MSTHS Napoleon (910 Third St. / sq)
 Owner GLCAP Telephone # 567-202-2345
 Owner Address 910 3rd St. Napoleon
 Contractor Children's dads Cell Phone # 419-360-0583
 Description of Work to be Performed Put up 12x10 gazebo kit +
attach to cement pad for Infant Toddler shade area
 Estimated Completion Date mid July Estimated Cost Volunteer

Demo Permit - \$100.00 - See Separate Form	(MDEMO 100.1700.46690)	\$
Zoning Permit - \$50.00	(MZON 100.1700.46690)	\$
Fence - \$25.00	(MZON 100.1700.46690)	\$
Garage and Shed 120 SF or less (Detached) - \$25.00	(MZON 100.1700.46690)	\$ <u>waived</u>
Parking lot /Driveway/Sidewalk/Curbing - \$0.00	(MZON 100.1700.46690)	\$
Drainage Permit/Outside Water/Sewer Repair - \$0.00	(MBLDG 510.0000.47300)	\$
1" Water Tap, 5/8" Meter, Copper Setter and Transmitter - \$1,200.00 (Outside City - \$5,680)	(MBLDG 510.0000.47300)	\$
1" Water Tap, 3/4" Meter, Copper Setter and Transmitter - \$1,300.00 (Outside City - \$5,820)	(MBLDG 510.0000.47300)	\$
1" Water Tap, 1" Meter, Copper Setter and Transmitter - \$1,400.00 (Outside City - \$5,960)	(MBLDG 510.0000.47300)	\$
1 1/2" Water Tap and Larger - See Operations Superintendent		\$
1" Meter, Copper Setter and Transmitter Without Tap - \$525.00	(MBLDG 510.0000.44730)	
3/4" Meter, Copper Setter and Transmitter Without Tap - \$440.87	(MBLDG 510.0000.44730)	
5/8" Meter, Copper Setter and Transmitter Without Tap - \$350.00	(MBLDG 510.0000.44730)	
Sewer Tap for All Commercial and Industrial Uses - \$600.00	(MBLDG 510.0000.44730)	\$
Sewer Tap Inspection Fee, M.F., Comm., Indust. 50 L.F. or Less - \$100.00	(MBLDG 510.0000.44730)	
Sewer Tap, M.F., Comm., Indust, 51 L.F. or More - \$100.00 + \$10.00 for each 50 L.F.	(MBLDG 510.0000.44730)	\$
Manufactured Home Court - \$87.00 Per Dwelling	(MBLDG 510.0000.44730)	
Sewer Main Extension in Right of Way Inspection - 2% of Construction Cost	(MBLDG 510.0000.44730)	\$
Inspection Fee Outside the Corporation Limits - Increase 50%	(MBLDG 510.0000.44730)	
TOTAL FEE:		\$ <u>Waived</u>

I FULLY UNDERSTAND THAT NO EXCAVATION, CONSTRUCTION OR STRUCTURAL ALTERATION, ELECTRICAL OR MECHANICAL INSTALLATION OR ALTERATION OF ANY BUILDING STRUCTURE, SIGN, OR PART THEREOF AND NO USE OF THE ABOVE SHALL BE UNDERTAKEN OR PERFORMED UNTIL THE PERMIT APPLIED FOR HEREIN HAS BEEN APPROVED AND ISSUED BY THE CITY OF NAPOLEON ZONING DEPARTMENT.
 I hereby certify that I am the Owner of the named property, or that the proposed work is authorized by the Owner of record and that I have been authorized by the Owner to make this application as his/her authorized agent and I agree to conform to all applicable laws of the jurisdiction. In addition, if a permit for Work described in this application is issued, I certify that the code official or the code official's authorized representative shall have the authority to enter areas covered by such permit at any reasonable hour to enforce the provisions of the code(s) applicable to such permit.

I HEREBY ACKNOWLEDGE THAT I HAVE READ AND FULLY UNDERSTAND THE ABOVE LISTED INSTRUCTIONS.

SIGNATURE OF APPLICANT: Maria Brown DATE: 6/21/23

BATCH #	CHECK #	DATE
---------	---------	------



Manufactured by:
 Backyard Discovery
 3305 Airport Drive, Pittsburg, KS 66762
 800-856-4445

Basepoint Business Centre: Rivermead Drive, Westlea, Swindon SN5 7EX Phone: 0800-118-2476
 J.P. Coenstraat 7, The Bridge, The Hague, 2595 WP, Netherlands Phone: 08005678990

12x10 ARLINGTON GAZEBO

MODEL # : 2206106

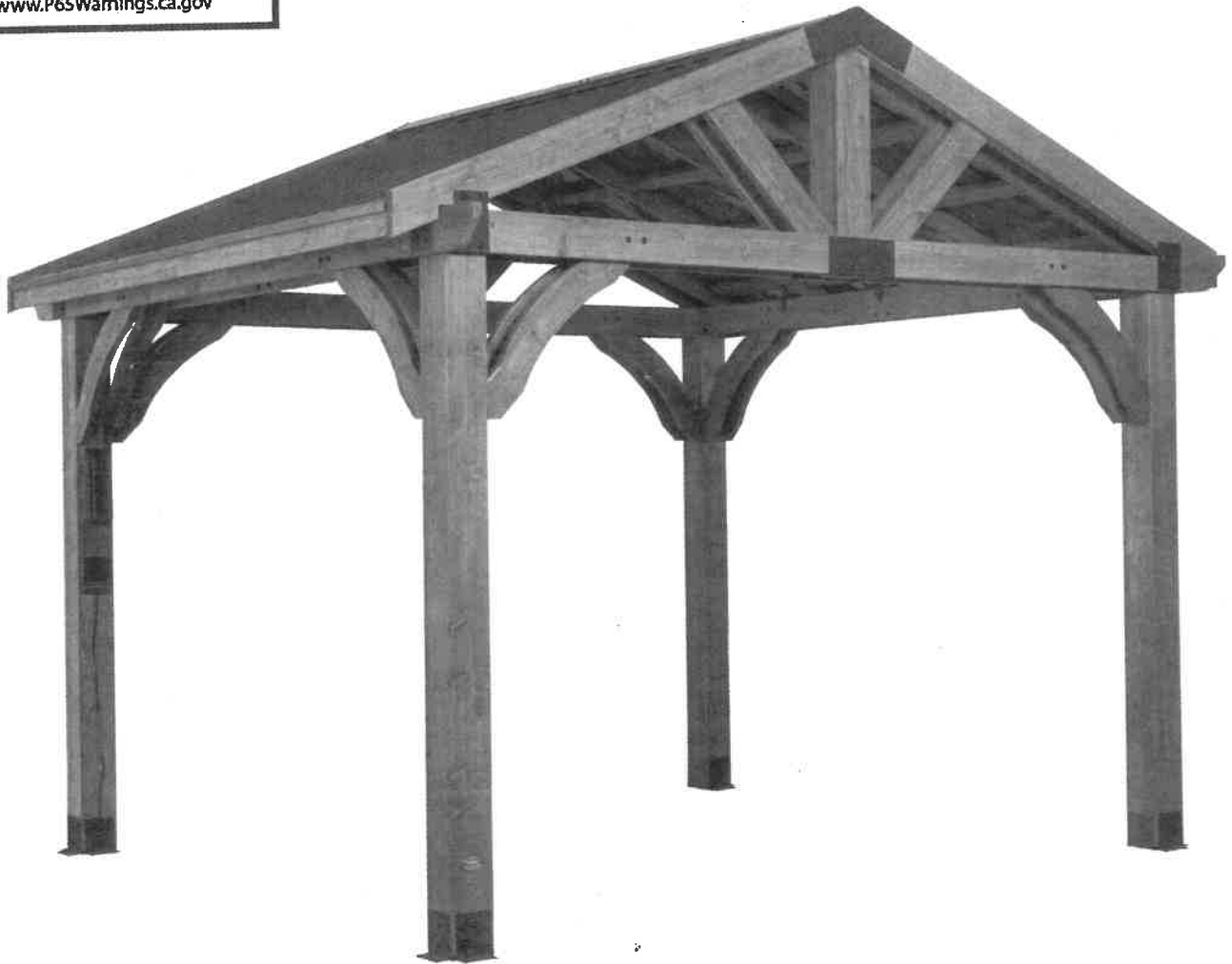

Please visit www.backyarddiscovery.com
 For the most up to date assembly manual, to register your product, or to order
 replacement parts *Para obtener instrucciones en español, visite*
www.backyarddiscovery.com



EASY STEP-BY-STEP
 3D INTERACTIVE INSTRUCTIONS
 DOWNLOAD THE FREE APP



INSTALLATION
 SERVICES
 AVAILABLE!
 See inside for details

OWNER'S MANUAL - BASIC SETUP DIMENSIONS & ASSEMBLY NOTES

It is critically important that you start with square and level footings, concrete pad or deck to attach your structure

- Pay close attention to the items needed for each step. Make sure you are using the correct hardware for each step. Using incorrect hardware may result in improper assembly
- Remember to double check for underground utilities and overhead electrical lines

Post mounts are provided with your structure which allows you to permanently install your structure to a pre-existing or new wood or concrete surface. See Anchor Instructions for further details and recommendations.

- The hardware to attach the post mounts to the structure is included.
- The hardware to mount the structure permanently to a concrete surface is included.
- The hardware to mount the structure permanently to a wood deck is NOT included and will need to be purchased separately. You must ensure there is ample structural support under the deck before permanently attaching.

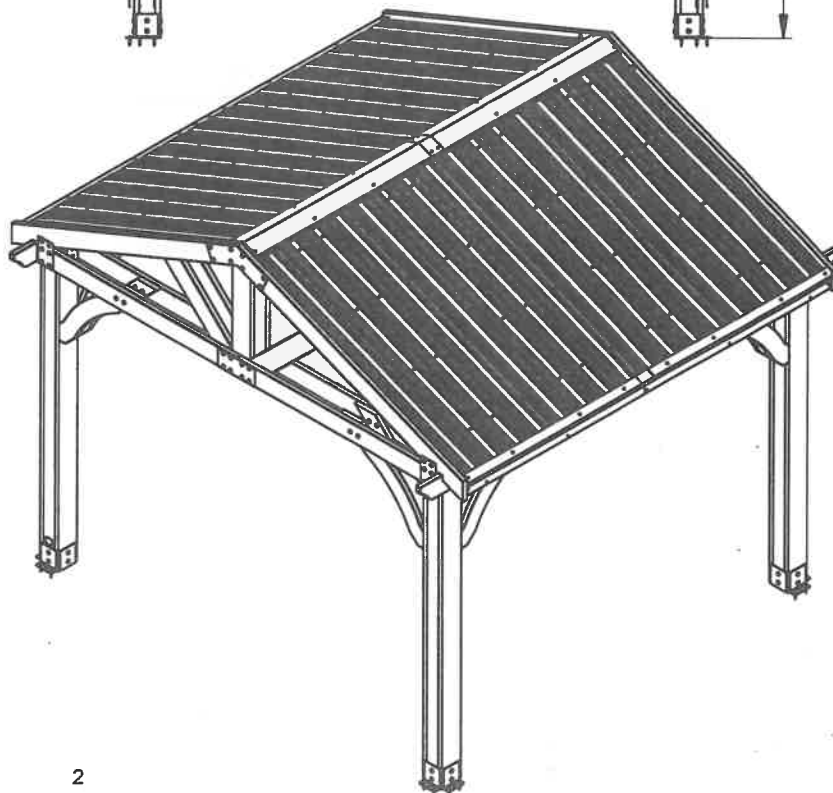
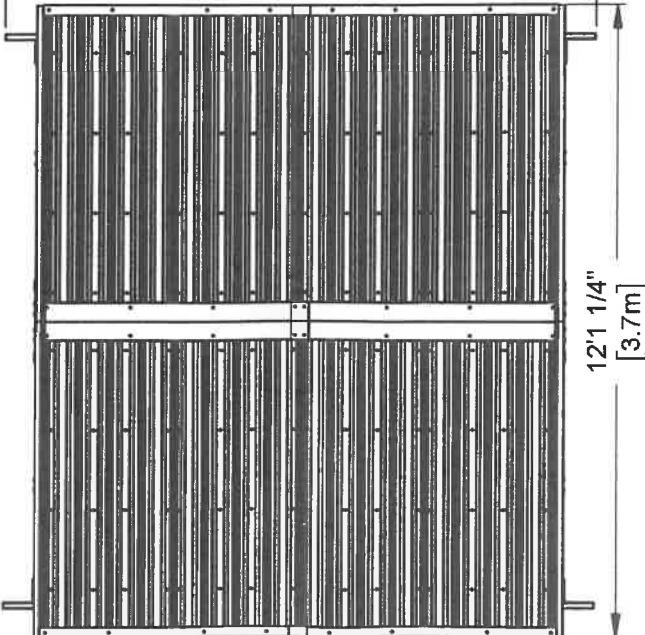
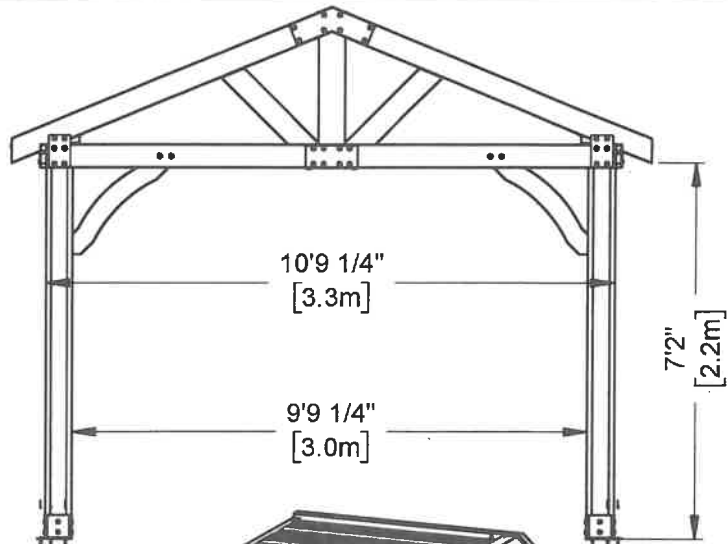
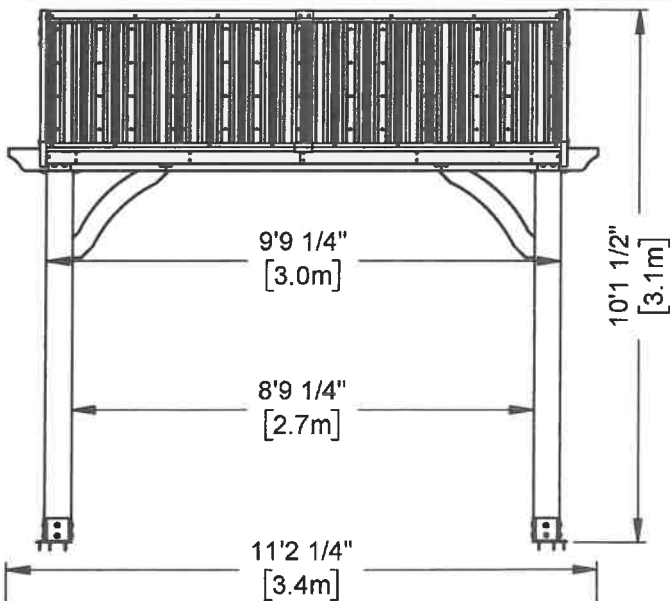

OWNER'S MANUAL - ANCHORING LAYOUT

